

P	LTR	DESCRIPTION	DATE	DWN	APVD
	B	REVISED PER ECR-10-007266	20APR2010	HMR	T.M
	C	REVISED	18OCT2019	K.T	E.I

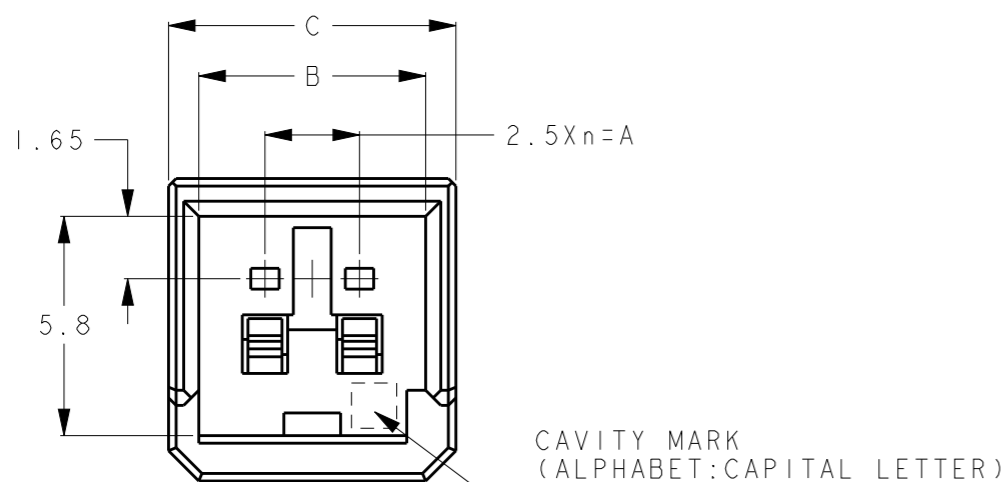

2POS(X-KEY): 1-1903129-2

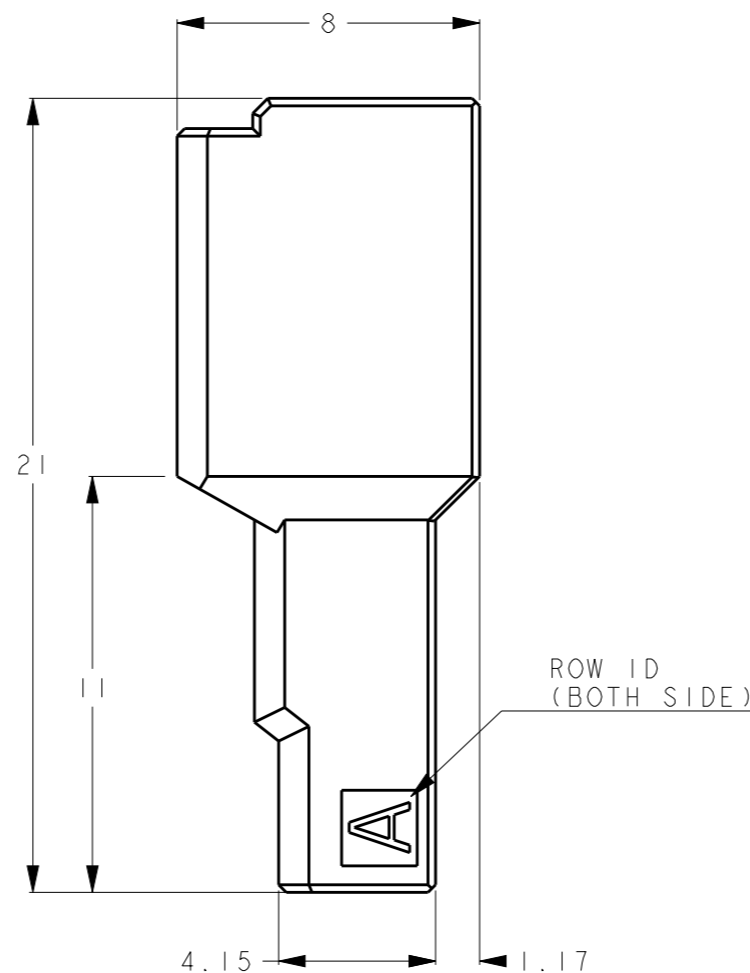
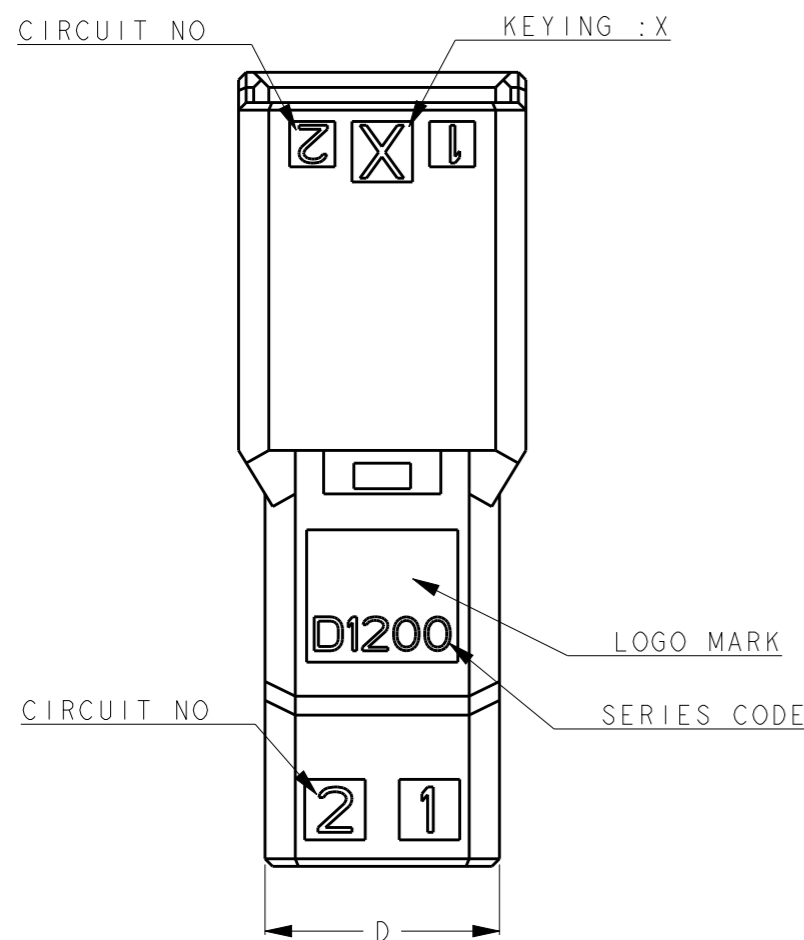

1. MATERIAL: GLASS FILLED THERMO PLASTIC POLYESTER(94V-0)
2. THE SHAPE, SIZE AND POSITION OF THE CHARACTER SHOW THE OUTLINE. THEY DON'T SHOW DETAILS.
3. CONTAMINATION: $\varnothing 1.0$ MAX.

1. 材料: ガラス入り熱可塑性ポリエステル樹脂(94V-0)
2. 文字の形状、大きさ、および位置については、大略を示すものであり、詳細を示すものではありません。
3. コンタミネーションは、 $\varnothing 1.0$ mm以下であること。

AS SHOWN 2POS : 1-1903129-2
8-1903129-2

NATURAL	2	X	I	2.5	6.0	7.6	6.2	8-1903129-2
BLACK	2	X	I	2.5	6.0	7.6	6.2	1-1903129-2
COLOR	POS.	KEY	n	A	B	C	D	PART NO

THIS DRAWING IS A CONTROLLED DOCUMENT.		DWN M. MAEBASHI 18APR2006	TE Connectivity	
DIMENSIONS: mm		CHK T. KUDO 18APR2006		
TOLERANCES UNLESS OTHERWISE SPECIFIED: $\pm 0.3, \pm 3^\circ$		APVD D. MITSUGI 18APR2006	NAME DYNAMIC D1200S 2.5mm PITCH TAB HSG, FREE HANGING TYPE 2 POS	
0 PLC \pm 1 PLC \pm 2 PLC \pm 3 PLC \pm 4 PLC \pm ANGLES \pm		PRODUCT SPEC 108-78268, 78298	RESTRICTED TO	
MATERIAL		APPLICATION SPEC 114-5377	SIZE A300779	DRAWING NO C=1903129
FINISH		WEIGHT	SCALE 5:1	SHEET 1 OF 1
		CUSTOMER DRAWING	REV C	

